

### LOCATION / LOS

#### LOCATION

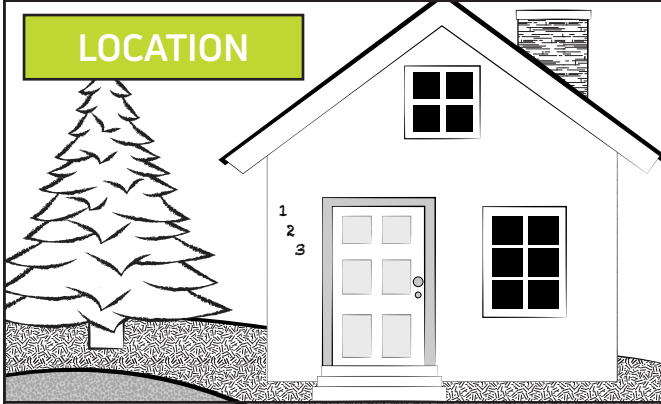

- Show full, frontal view of the home from the street:
  - Show customer's address
  - Show mailbox if necessary
- Do not take pictures of the customer, customer documents, or customer vehicle/license plate

#### LINE OF SIGHT

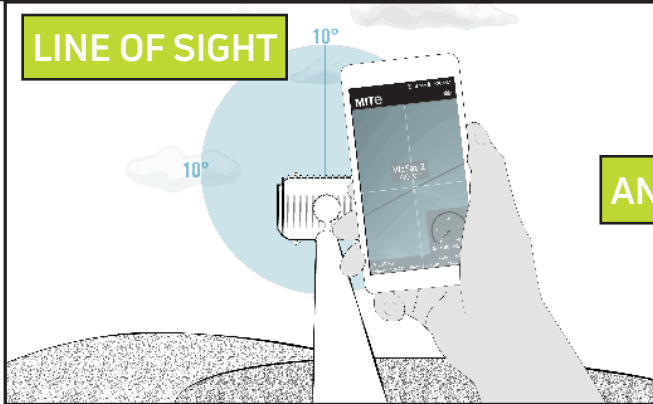

- Show a clear view of the southern sky toward the TRIA
- Take at least one photo that shows the line of sight from:
  - Top of the boom arm (where it connects to the reflector) toward the TRIA and/or
  - 1-2 feet behind the antenna reflector

#### AND/OR

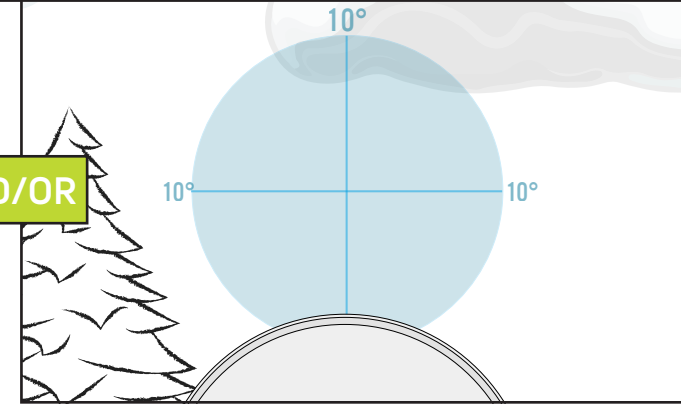

- Line of Sight should be:
  - Clear in all directions by 10 degrees
  - Clear of tree growth, seasonal foliage changes, and future development

### OUTDOOR UNIT (ODU)

#### BACK ASSEMBLY

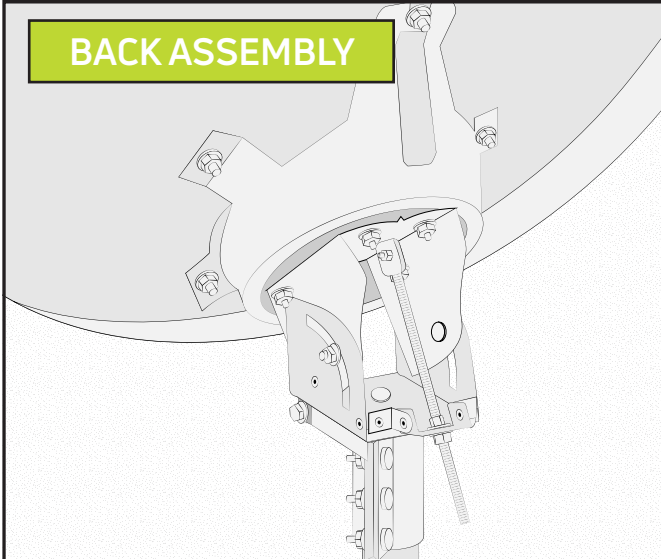

- Show the entire back assembly of the ODU installed:
  - Tighten all nuts and bolts, including collar bolts and elevation rod nuts
  - Use all hardware as designed for assembly
  - Use only approved components (matching reflector, AZ/EL and hardware)
  - Set skew according to the information on the work order

#### MOUNT

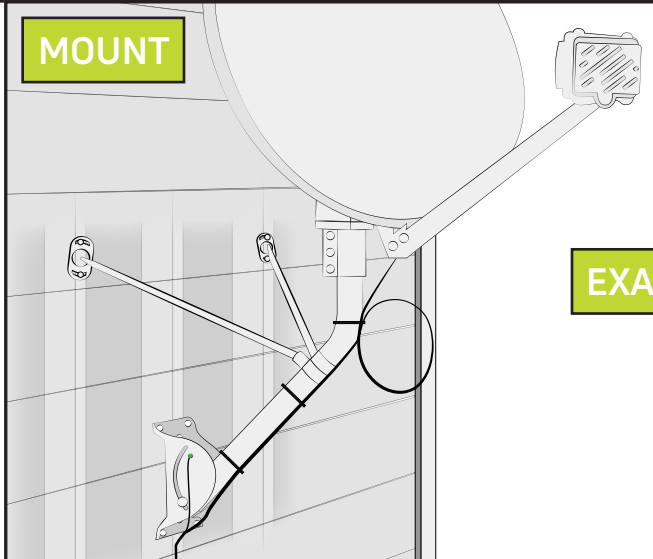

- Show correct installation of one of our approved mounts:
  - Wall / Roof Mount
  - Pole Mount
  - Side "S" Mount
  - Low Profile "Stub" Mount
  - Under Eave Mount
  - Brick Mount
  - Non-Pen Mount

#### EXAMPLES

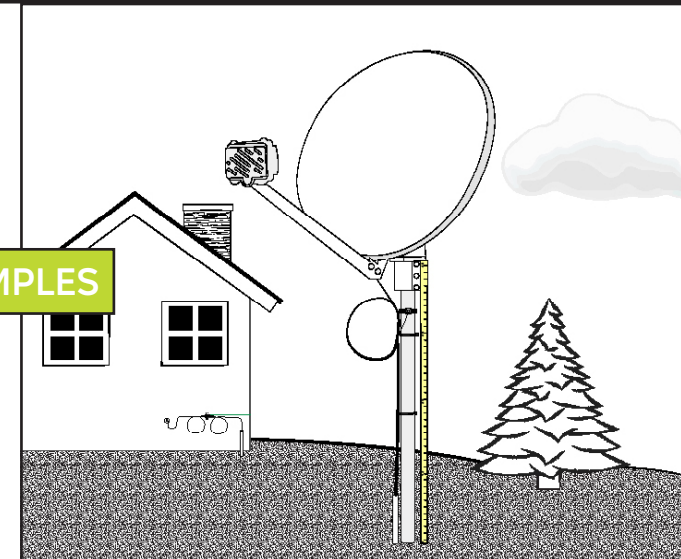

#### Reference "Mount Types" section for specific mount standards

- All information detailed in the mount profile must be visible in the installation photo
- Submit as many pictures as necessary to depict all installation requirements

### GROUND

#### GROUND SOURCE

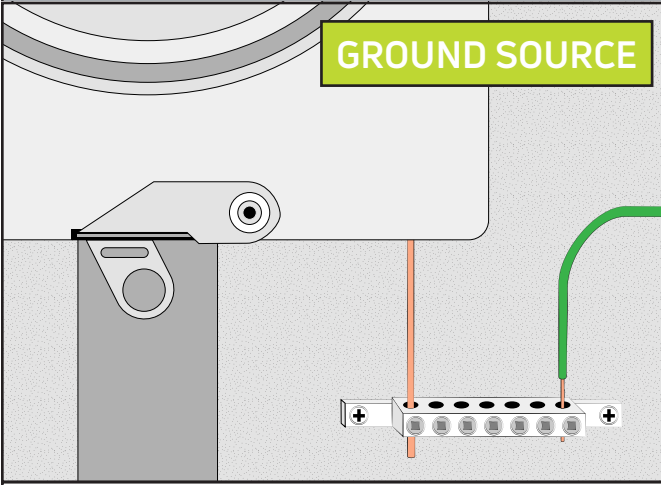

- Show a UL listed device attached to an NEC-approved ground source
  - IBT (required if present), #6 bare copper wire, back-bonded grounding electrode, metallic raceway, meter box, grounded I-beam, approved main water line
- Use matching metals (ex. copper to copper)
- Do not impede the opening of the meter box door
- Do not share ground sources (Note: each IBT port is an available ground source)
- Scrape paint to allow metal to metal contact

#### GROUND BLOCK

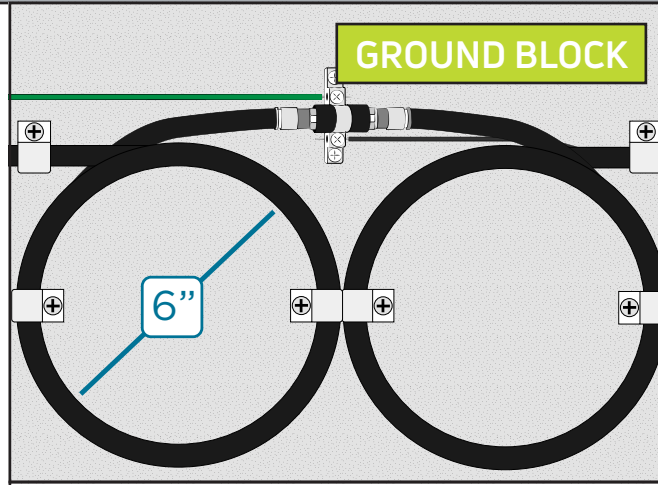

- Show the installation of a UL listed, 3Ghz rated ground block:
  - Install compression connectors, torque to 30 in. lbs.
  - Use weather boots on both sides of the ground block
  - Form 6" diameter service loops
  - Attach ground block directly to structure (2 screws)
  - Run the #10 gauge solid copper ground wire as straight and short as possible, with minimal bends
  - Connect messenger and ground wire to ground block

#### GROUND RUN

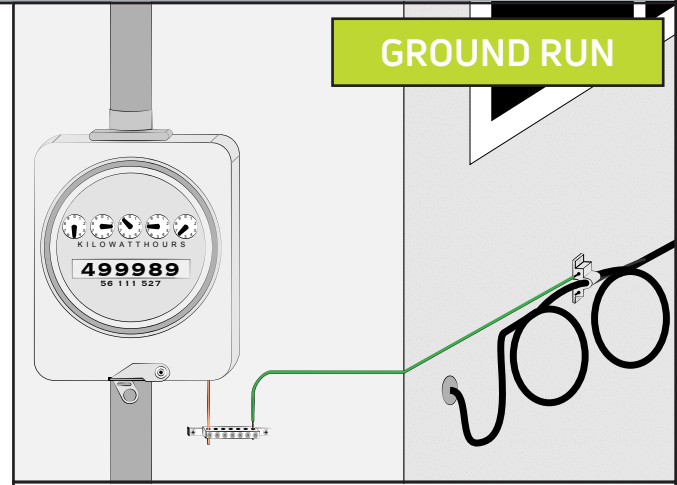

- Show the entire run from the ground block to the ground source:
  - Must be less than 20 feet
  - May require multiple photos to demonstrate entire ground run
    - » If multiple photos are necessary, they must visually overlap so the ground run can be followed

### CABLE

#### CABLE RUN

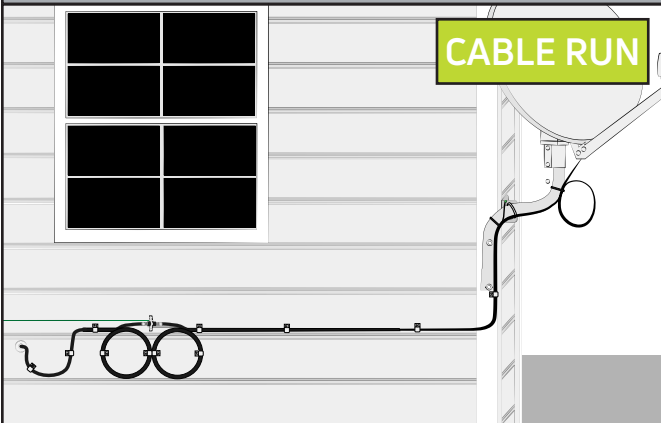

- Show that the cabling:
  - Is <150', neat, and follows the lines of the house
  - Is attached using only screw clips
  - Is continuous and does not use in-line barrels, excluding the ground block and wall plate
  - Never bend the cable to 90 degree angles

#### CABLE TYPE

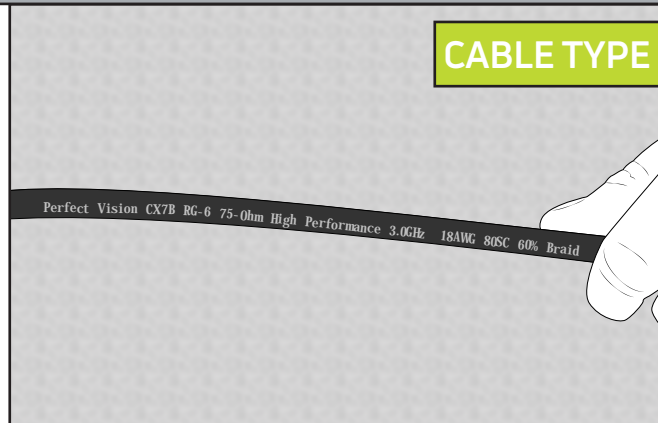

- Show a close-up of cable markings proving:
  - Cable type and model number
  - Solid copper, rated to 3GHz, 75 Ohm, 60% braid
  - Cable is in good condition

#### POINT OF ENTRY

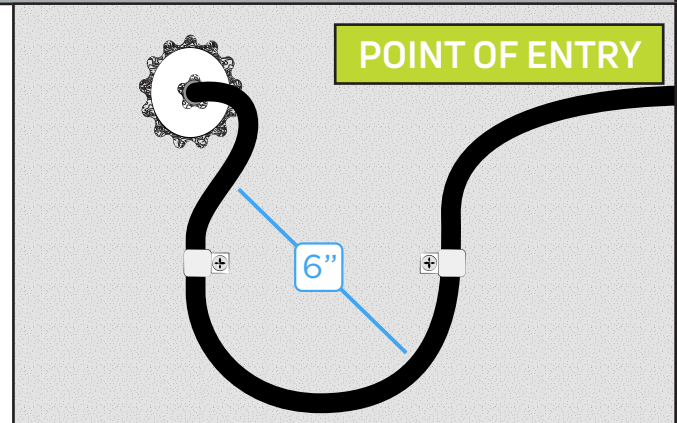

- Show point where cable enters the building:
  - Form a J-loop prior to entry
  - Seal the hole with silicone and an approved bushing
  - Form cable bends with a diameter of at least 6"
  - Use only screw clips to secure the cable
  - Never bend the cable to 90 degree angles

### WALL MOUNT

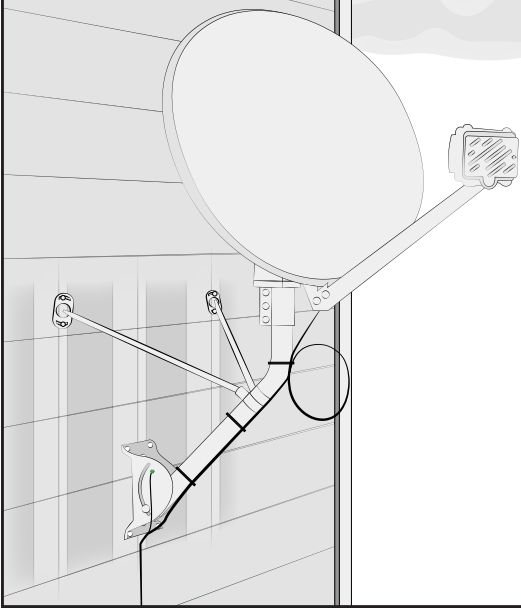

- Attach to an approved, structurally sound surface (wood or composite siding only)
- Mount antenna so that the bottom of the reflector is at least 4' above a walking surface
- ODU is at least 3' from electrical panel and 20' from power lines
- Use only approved and matching ODU hardware
- Secure the footplate to the wall with:
  - Two 3" lags through center holes into stud
  - Four 2" lags through corner holes
- Position monopoles 2" below the bend, at an upward angle, forming a tripod
- Secure monopole plates to adjacent studs using two 3" lags
- Seal all drilled holes with silicone
- Zip-tie cable to the mast, including a 6" diameter service loop
- Connect the messenger/ground wire to a green ground screw on the footplate
- Tighten all hardware completely

### ROOF MOUNT

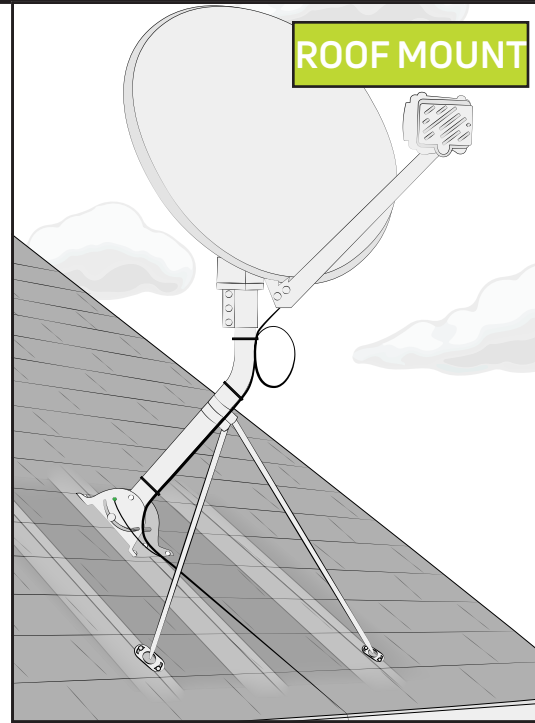

- Attach to an approved, structurally sound surface (asphalt shingles only, sloped roof, close to the roof's edge, ideally not over living space)
- ODU is at least 3' from electrical panel and 20' from overhead power lines
- Use only approved and matching ODU hardware
- Secure the footplate to the roof with:
  - Two 3" lags through center holes into rafter
  - Four 2" lags through corner holes
- Position monopoles 2" below the bend, at a downward angle, forming a tripod
- Secure monopole plates to adjacent rafters using two 3" lags
- Seal all drilled holes with tar-based sealant
- Zip-tie cable to the mast, including a 6" diameter service loop
- Connect the messenger/ground wire to a green ground screw on the footplate
- Tighten all hardware completely

### SIDE "S" MOUNT

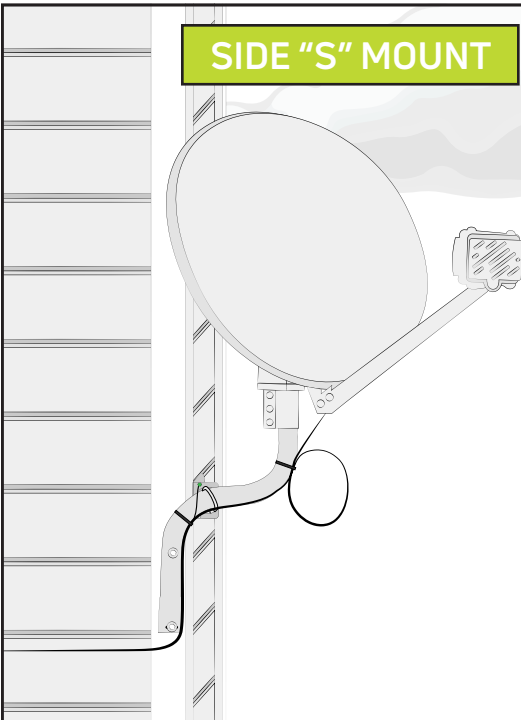

- Attach to an approved, structurally sound surface (wood or composite siding only, southern-facing corner, avoid touching the eave/roof with antenna)
- Mount antenna so that the bottom of the reflector is at least 4' above a walking surface
- ODU is at least 3' from electrical panel and 20' from power lines
- Use only approved and matching ODU hardware
- Secure the footplate to a corner stud with:
  - Two 6" lags on S-tube
  - Two 3" lags on L-bracket
- Seal all drilled holes with silicone
- Zip-tie cable to the mast, including a 6" diameter service loop
- Connect messenger/ground wire to a galvanized strap or green ground screw
- Tighten all hardware completely

### LOW PROFILE "STUB" MOUNT

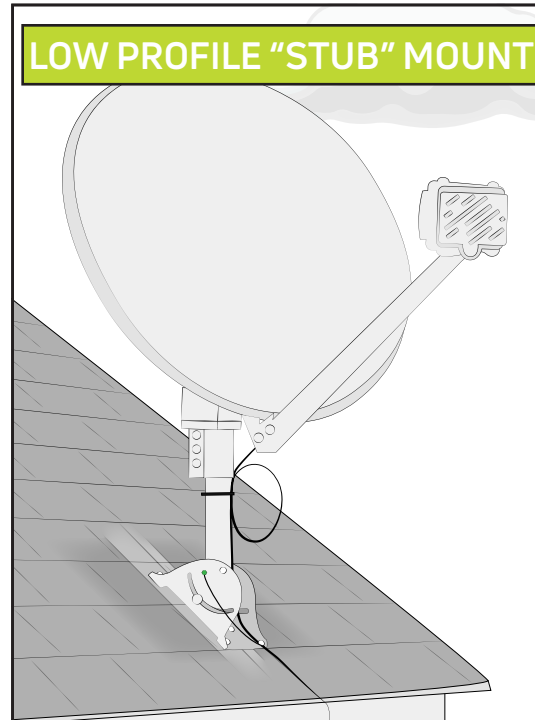

- Attach to an approved, structurally sound surface:
  - Sloped roofs only
  - Asphalt shingles only
  - Close to the roof's edge
  - Ideally not over living space
- ODU is at least 3' from electrical panel and 20' from power lines
- Use only approved and matching ODU hardware
- Secure the footplate to the roof with:
  - Two 3" lags through center holes into rafter
  - Four 2" lags through corner holes
- Seal all drilled holes with tar-based sealant
- Zip-tie cable to the mast, including a 6" diameter service loop
- Connect the messenger/ground wire to a green ground screw on the footplate
- Tighten all hardware completely

### POLE MOUNT

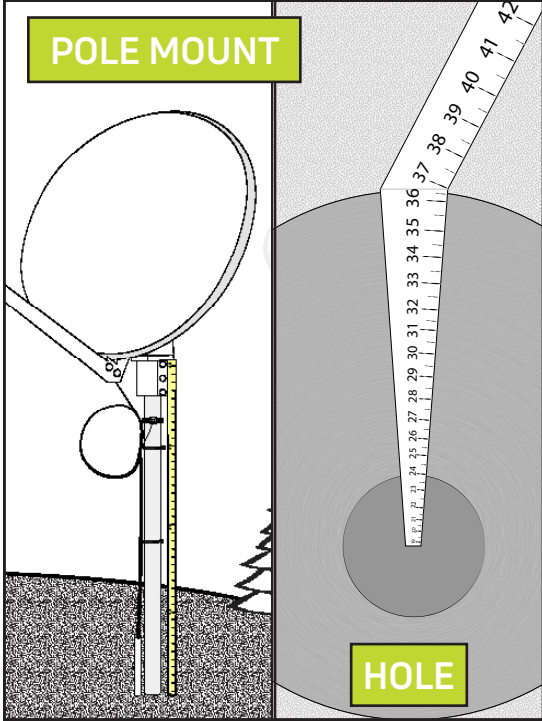

#### Pole Mount

- Install in stable, solid ground
- Use an approved pole:
  - 2" OD, 9 gauge, or 2 3/8" OD, Schedule 40
  - Galvanized, with an anti-spin device
  - 84" or 96" in length
- Photo displays measuring tape along pole:
  - If 7ft pole: 4' above walking surface
  - If 8ft pole: 5' above walking surface
- Use 150 lbs. of concrete (3 bags)
- Use 2 sweeps (1 at pole, 1 at house)
- If non-flooded cable is used, it must be buried in conduit
- Zip-tie cable to the pole, including a 6" diameter service loop
- Connect the messenger/ground wire to a galvanized ground strap
- Tighten all hardware completely

#### Hole

- Photo displays the hole measures 36" from the bottom to the top
- Hole should appear 12" in diameter and bell-shaped at the bottom

### BRICK MOUNT

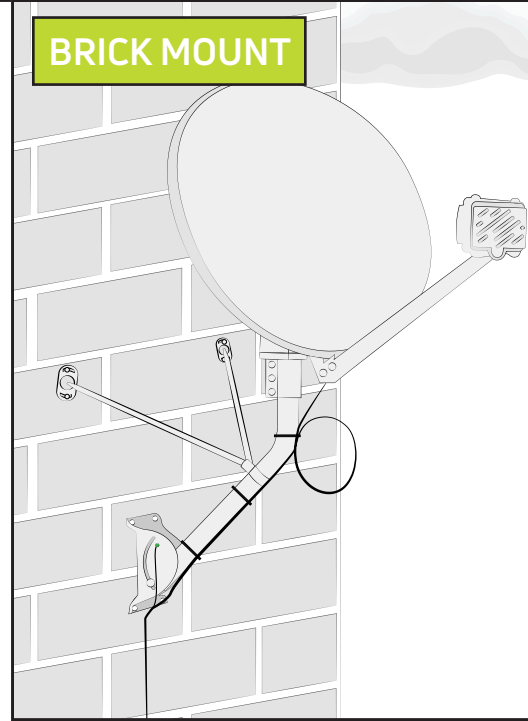

- Attach to an approved, structurally sound surface (load bearing wall, 28" away from corner/door/window/top of wall, no chimneys)
- Mount antenna so that the bottom of the reflector is at least 4' above a walking surface
- ODU is at least 3' from electrical panel and 20' from power lines
- Use only approved and matching ODU hardware
- Secure footplate using four 2" lags in corner holes and proper anchors
- Position monopoles 2" below the bend, at an upward angle, forming a tripod
- Monopole plates secured by two 2" lags, using proper anchors
- Lags must not be drilled into mortar, or more than two lags in one brick
- Seal all drilled holes with silicone
- Zip-tie cable to the mast, including a 6" diameter service loop
- Connect messenger/ground wire to a green ground screw on the footplate
- Tighten all hardware completely

### UNDER EAVE MOUNT

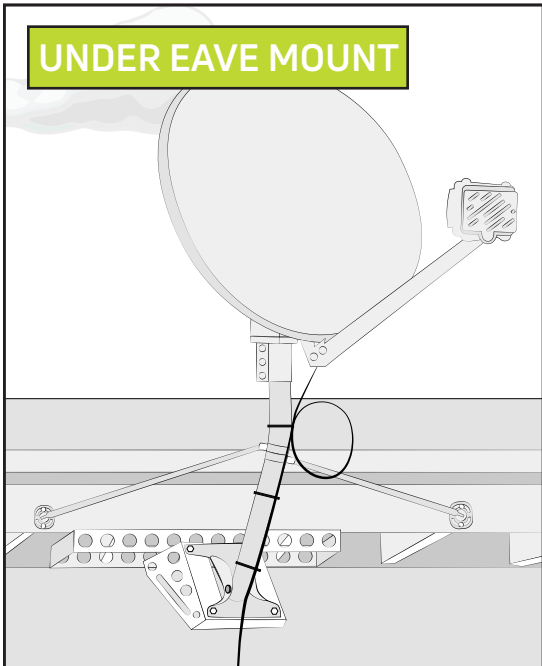

- Attach to an approved, structurally sound surface
- ODU is at least 20' from power lines
- Use only approved and matching ODU hardware
- The following options are available:
  - Slearo mount secured with four 3" lags
  - J-Mount secured with two 3" lags in center holes, and four 2" lags in corner holes
  - EM7 mount secured with five 3" lags
- Install the monopole per manufacturer's instructions
- Secure the monopole plates to adjacent rafters using two 2" lags
- Seal all drilled holes with silicone
- Zip-tie cable to the mast including a 6" diameter service loop
- Connect the messenger/ground wire to a green ground screw on the footplate
- Tighten all hardware completely

### NON-PEN MOUNT

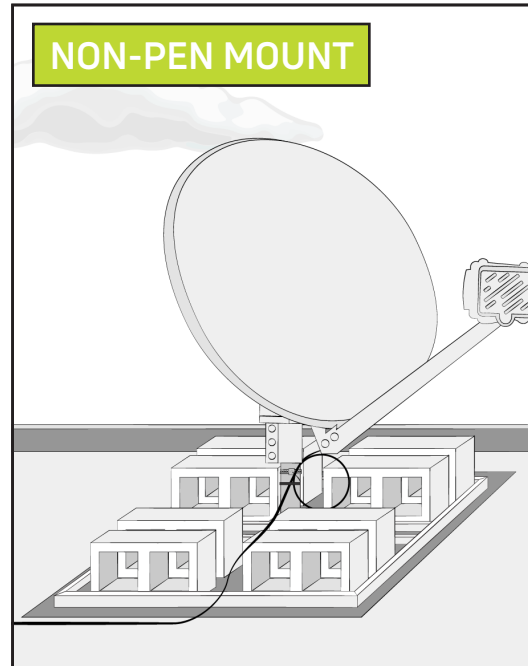

- Install on an approved, structurally sound, flat roof only
- Use a protective mat
- ODU is at least 3' from electrical panel and 20' from power lines
- Use only approved and matching ODU hardware
- If using monopoles, position the collars 2" below the bend, at a downward angle, forming a tripod.
- Zip-tie cable to the mast, including a 6" diameter service loop
- Connect messenger/ground wire to either:
  - A galvanized strap on the mast, or
  - A green ground screw on the footplate
- Use a minimum of eight 28-pound cinder blocks for ballast
- Tighten all hardware completely